

FLATIRON STEEL



COVERING WHAT MATTERS MOST

TRIM SPECS

Standing Seam



FLATIRON STEEL

FLASHING DETAILS - STANDING SEAM

PENCIL RIB

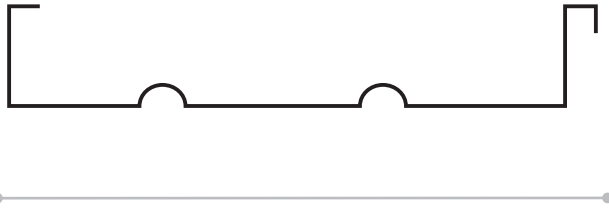

STRIATIONS

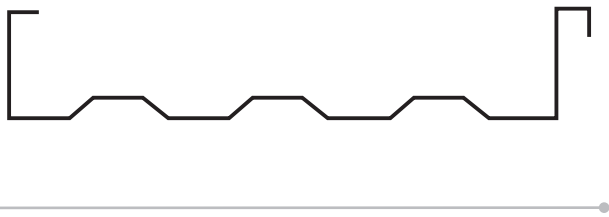

PANEL PROFILES

1 1/2" & 2" MECHANICAL LOCK



1 1/2" Mechanical Lock Available Widths: 12", 16", 20"

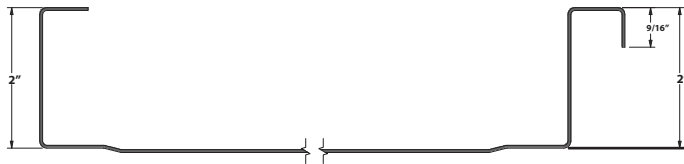

2" Mechanical Lock Available Widths: 14.1", 18.1"



- UL Certified (1 1/2" Nail, 1 3/4" Snap, 2" Mechanical)
- UL 580 Class 90 wind uplift
- UL 2218 Class 4 hail impact
- UL790 Class A fire rating

**Please Note: Panel design pressure, wind uplifts and test reports are for specific deck attachments, materials gauges, clip spacing and panel widths.*

1 1/2" & 1 3/4" SNAP LOCK

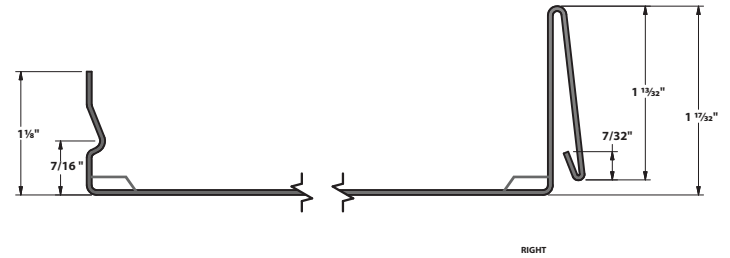

1 1/2" Snap Lock Available Widths: 15.6", 19.6"

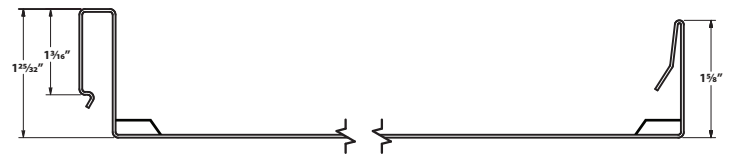

1 3/4" Snap Lock Available Widths: 13.8", 17.8"

1" & 1 1/2" NAIL STRIP

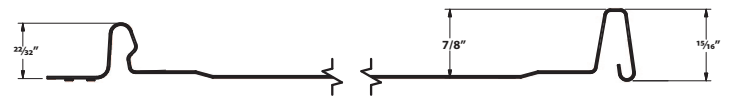

1" Nail Strip Available Widths: 11.9", 15.9", 19.9"

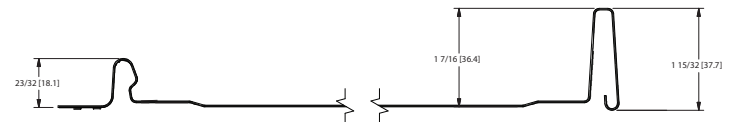

1 1/2" Nail Strip Available Widths: 14.6", 18.6"

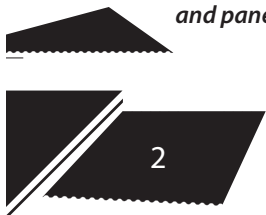



FLATIRON STEEL

FLASHING DETAILS - STANDING SEAM

All trim specifications are designed to be used with Flatiron Steel standing seam panels.

When needed, custom trim is available in all colors, 10'-0" length, and will be priced based upon the desired profiles girth (width before bending).

Material used for standing seam panels is manufactured in 22, 24, and 26 gauge painted, Galvalume, and G90 Galvanized finishes. Also available in 22 gauge Core-Ten™ or Cold Roll and pure copper (16oz, 20oz & 24oz).

Warranty information that's provided, should be used as a guideline. Complete limited warranty information is available upon request.



The companies listed as Energy Star® Partner, have determined that those products meet the Energy Star® guidelines for energy efficiency.

KYNAR 500® is a registered trademark of Arkema, Inc.
 HYLAR 5000® is a registered trademark of Solvay Solexis.
 GALVALUME® is a registered trademark of BEIC.
 ULTRA-Cool® is a registered trademark of BASF Corporation
 VALSPAR® is a registered trademark of Valspar
 Truzinc® is a registered trademark of Steelscape Inc.
 Rezibond® is a registered trademark of Steelscape Inc.
 Duracoat® is a registered trademark of Duracoat Inc.

COIL SUPPLIERS

Contact Flatiron Steel to obtain color charts and samples.

Flatiron Steel **24 Gauge**

- Steel Yield Stress: 50,000ksi (Grade D)
- Substrate: AZ50
- Paint System: Duracoat Durapon 70™ PVDF
- **35-Warranty** / ENERGY STAR PARTNER
- Weight: 1.00 lbs/sf.

Rezibond™ Bonderized (Flatiron Steel Inc.) **24 Gauge**

- Steel Yield Stress: 50,000psi (Grade D)
- TruZinc® Galvanized Steel Base
- **Warranty:** None
- Rezibond™ is a product to replace bare bonderized material used in the rain water goods industry. This product has a lightly-textured surface that possesses a dark grayish-to-black color.*
- Weight: 1.00 lbs/sf.
- *Not a regular stocked item*

Coated Metals Group (CMG) **24/26 Gauge**

- Steel Yield Stress: 50,000ksi (Grade D)
- Substrate: AZ50
- Paint System: Duracoat ULTRA-CLAD® (Kynar 500®/Hylar 5000®)
- **35-Year Warranty** / ENERGY STAR PARTNER®
- 26 Gauge available in certain colors. Call for availability.
- Weight: 1.00 lbs/sf. (24 Gauge)
- Weight: .75 lbs/sf. (26 Gauge)

Sheffield Metals Int. **24/26 Gauge**

- Steel Yield Stress: 50,000ksi (Grade D)
- Substrate: AZ50
- Paint System: Valspar®, COOLR, (Kynar 500®/Hylar 5000®)
- **35-Year Warranty** / ENERGY STAR PARTNER®
- 26 Gauge available in certain colors. Call for availability.
- Weight: 1.00 lbs/sf. (24 Gauge)
- Weight: .75 lbs/sf. (26 Gauge)

Core-Ten™ Weathering Steel (Flatiron Steel Inc.) **22 Gauge**

- Steel Yield Stress: 50,000ksi (Grade D)
- Untreated, Cold Rolled Steel
- Lifespan Alloys: Copper, Nickel, Chromium
- **Warranty:** None (Typical Lifespan 40-80 years)
- Weight: 1.25 lbs/sf.

Cold Rolled Weathering Steel (Flatiron Steel Inc.) **22 Gauge**

- Steel Yield Stress: 50,000ksi (Grade D)
- Untreated, Cold Rolled Steel
- **Warranty:** None (Typical Lifespan 30-60 years)
- Weight: 1.25 lbs/sf.
- *Not a regular stocked item*

Copper (Flatiron Steel Inc.) **16, 20 & 24 oz.**

- Tensile Strength: 32-40,000psi
- Pure Copper
- **Warranty:** None
- Weight (16 oz): 1.0 lbs/SF (20 oz): 1.25 lbs/sf. (24 oz): 1.5/lbs/sf.
- *Not a regular stocked item*
- *All weights listed are 24 Gauge.*

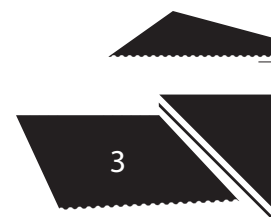



FLATIRON STEEL

FLASHING DETAILS

STANDING SEAM

RADIUSED STANDING SEAM PANELS

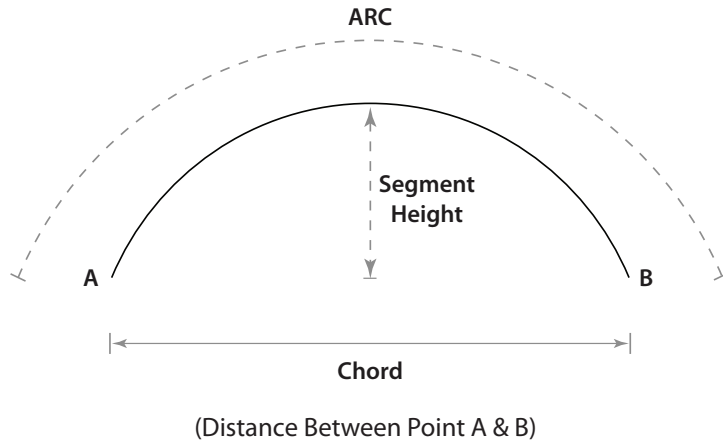
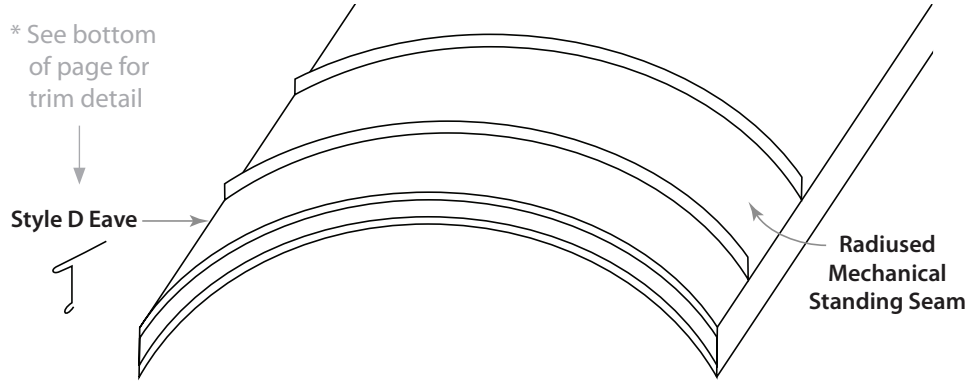

All three measurements are needed to calculate radius. Radiused panels are only available in 1½" Mechanical Seam.

Certain limitations apply. Call for details.

Hip/Ridge

Item #	Girth	Length	Weight
FS174	12"	10'0"	9.96 lbs.

Style D Eave

Item #	Girth	Length	Weight
FS175	8"	10'0"	6.64 lbs.

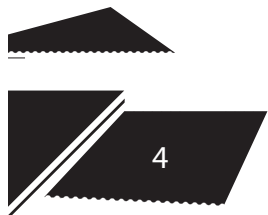
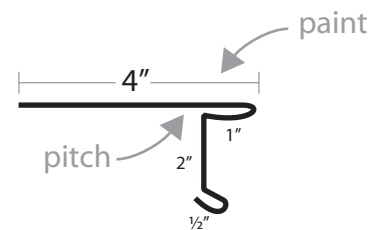
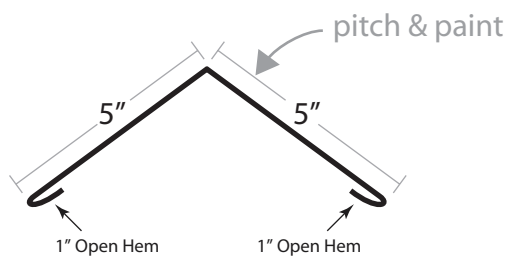

Northern Colorado | P: 970.284.6306 | F: 970.284.6345
 Colorado Springs | P: 719.591.1114 | F: 719.591.1986



STANDING SEAM

Eave (Style A Fascia)

Item #	X	Girth	Length	Weight
FS103A	3½" (2x4)	6"	10'0"	4.9 lbs.
FS103C	5½" (2x6)	8"	10'0"	6.7 lbs.
FS103E	7½" (2x8)	10"	10'0"	8.3 lbs.

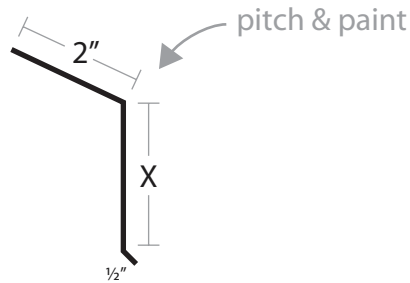

High Profile Sidewall

Item #	X	Girth	Length	Weight
FS159A	1"	9¼"	10'0"	7.68 lbs.
FS159B	1½"	9¾"	10'0"	8.09 lbs.
FS159C	1¾"	10"	10'0"	8.30 lbs.
FS159D	2"	10¼"	10'0"	8.51 lbs.

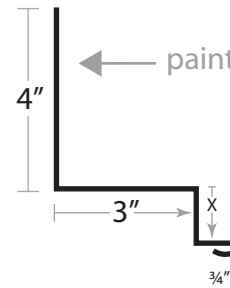

High Profile Gable

Item #	Y	X	Length	Girth	Weight
FS157A	1"	3"	10'0"	9½"	7.89 lbs
FS157B	1½"	3½"	10'0"	10"	8.30 lbs
FS157C	1¾"	3¾"	10'0"	10¼"	8.51 lbs
FS157D	2"	4"	10'0"	10½"	8.72 lbs

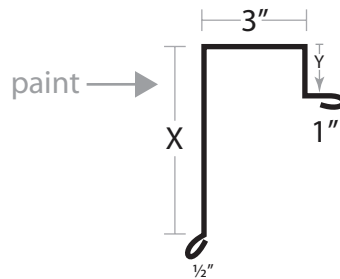

Locking Sidewall

Item #	Girth	Length	Weight
FS160	9¼"	10'0"	7.68 lbs.

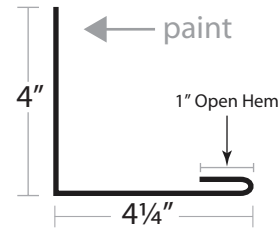

Locking Gable / Rake

Item #	Girth	Length	Weight
FS158	8"	10'0"	6.64 lbs.

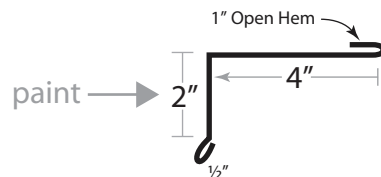

Locking Endwall

Item #	Girth	Length	Weight
FS161	10"	10'0"	8.30 lbs.

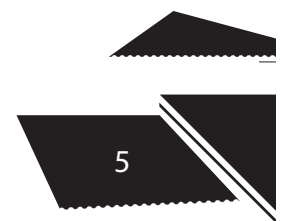
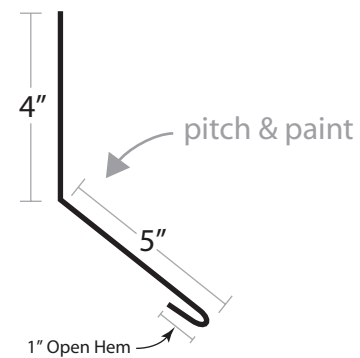



STANDING SEAM

Locking Front Cap

Item #	X	Girth	Length	Weight
FS162A	3"	10"	10'0"	8.30 lbs.
FS162B	5"	12"	10'0"	9.96 lbs.
FS162C	7"	14"	10'0"	11.62 lbs.

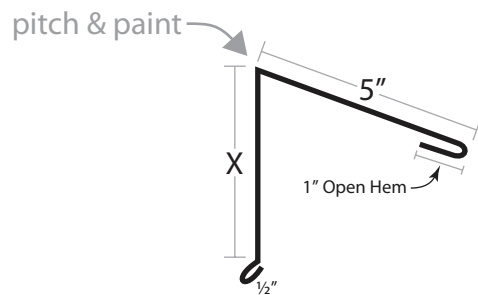

Locking Transition

Item #	Girth	Length	Weight
FS166	14"	10'0"	11.62 lbs.

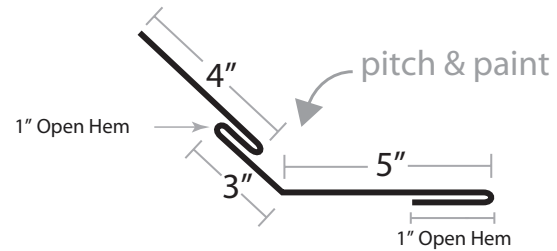

Standing Seam J-Metal

Item #	X	Girth	Length	Weight
FS165A	1"	6"	10'0"	4.98 lbs.
FS165B	1 1/2"	6 1/2"	10'0"	5.40 lbs.
FS165C	1 3/4"	6 3/4"	10'0"	5.60 lbs.
FS165D	2"	7"	10'0"	5.81 lbs.

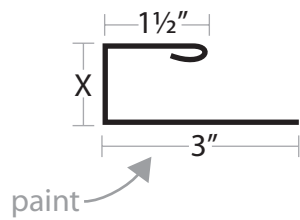

Locking Chimney / Skylite Flashing

Item #	Girth	Length	Weight
FS167	13"	10'0"	10.79 lbs.

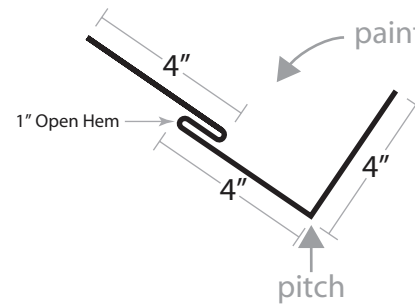

Locking V-Valley

Item #	Girth	Length	Weight
FS168	20"	10'0"	16.60 lbs.

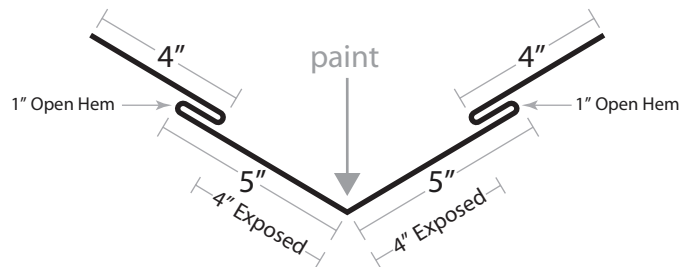

Locking W-Valley

Item	Girth	Length	Weight
FS169	22"	10'0"	18.26 lbs.

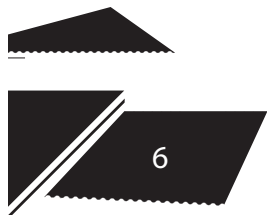
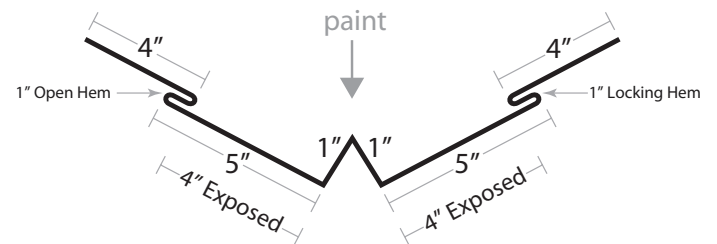



STANDING SEAM

One Sided Locking W-Valley

Item	Girth	Length	Weight
FS177	22"	10'0"	18.26 lbs.

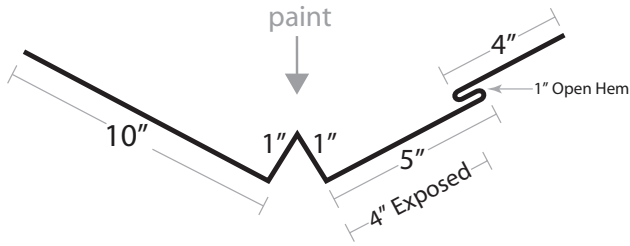

Starter

Item #	Girth	Length	Weight
FS171	5"	10'0"	4.15 lbs.

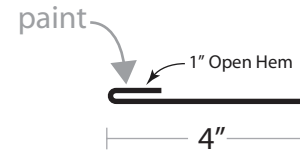

* To be used in conjunction with:
FS158 & FS160

Plain Valley

Item	Girth	Length	Weight
FS170	20"	10'0"	16.60 lbs.

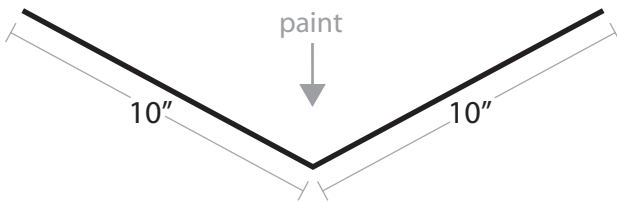

Raised Cleat

Item	Girth	Length	Weight
FS172	3"	10'0"	2.49 lbs.

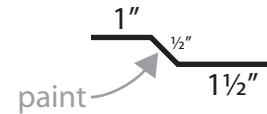

* To be used in conjunction with:
FS103 & FS170

One Sided Locking V-Valley

Item #	Girth	Length	Weight
FS176	20"	10'0"	16.60 lbs.

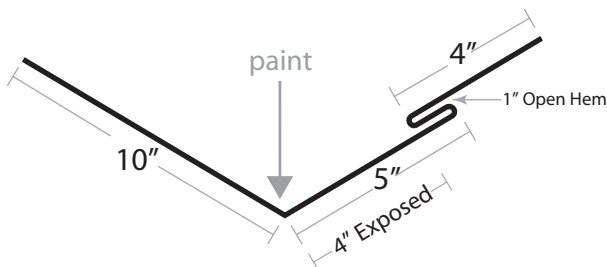

Z-Closure

Item #	X	Girth	Length	Weight
FS173A	1"	3"	10'0"	2.49 lbs.
FS173B	1 1/2"	3 1/2"	10'0"	2.91 lbs.
FS173C	1 3/4"	3 3/4"	10'0"	3.11 lbs.
FS173D	2"	4"	10'0"	3.32 lbs.

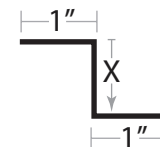



Standing Seam Upper Transition

Item #	Girth	Length	Weight
FS179	13"	10'0"	12.45 lbs.

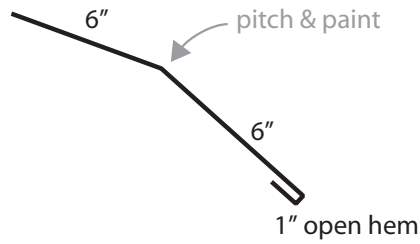

Standing Seam Lower Transition

Item	Girth	Length	Weight
FS178	13"	10'0"	12.45 lbs.

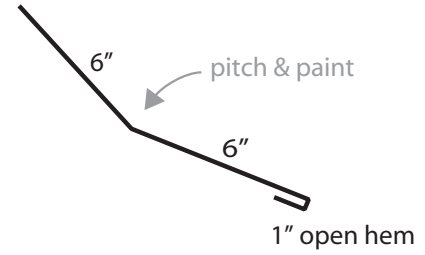

Standing Seam Prow Gable

Item #	X	Y	Girth	Length	Weight
FS164A	1½"	3½"	20"	10'0"	16.60 lbs
FS164B	2"	4"	21"	10'0"	17.50 lbs
FS164C	2¼"	4¼"	21½"	10'0"	17.91 lbs
FS164D	2½"	4½"	22"	10'0"	18.33 lbs

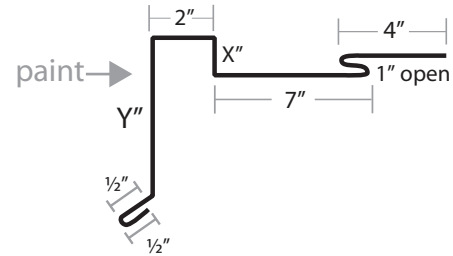

Northern Colorado | P: 970.284.6306 | F: 970.284.6345
 Colorado Springs | P: 719.591.1114 | F: 719.591.1986





11500 21st Street | Greeley, Colorado 80634 | 970.284.6306
7885 Red Granite Loop | Colorado Springs, Colorado 80939 | 719.591.1114

www.FLATiRONsteel.com

2017

